



INSTRUCTION MANUAL IM-304
For Tuning Plugs and Caps used on the
7FA.05 Load Coupling

Applicable Equipment

Frame 7FA.05 Gas Turbine Load Coupling Tuning Cap
Frame 7FA.05 Gas Turbine Load Coupling Tuning Plug
Frame 7FA.05 Gas Turbine Load Coupling Tuning Cap Installation Tool

Applicable GE Ordering Sheet Part Numbers

105T5274P001
105T5274P002
105T5274P003

GE Power Generation		GENERAL ELECTRIC COMPANY	
<u>VENDOR SUPPLIED</u>			
GE NOT TO REVISE. GE REVISION LEVEL IS SHOWN ON THIS APPLIQUE. THIS DOCUMENT IS FILED UNDER THE GE DRAWING NUMBER. THIS DOCUMENT SHALL BE REVISED IN ITS ENTIRETY. ALL SHEETS OF THIS DOCUMENT ARE THE SAME REVISION LEVEL AS INDICATED IN THIS VENDOR SUPPLIED DRAWING APPLIQUE.			
MLI:		____ OF ____	
GE SIGNATURES	DATE	GE DRAWING NUMBER	REV
CHECKED:		373A4063	B
ISSUED:			

The Riverhawk Company reserves the right to update this document without dissemination or notice.
The latest revision may be obtained by contacting Riverhawk Company or thru www.riverhawk.com.

215 Clinton Road
New Hartford, NY 13413
Tel: +1 315 768 4855
Fax: +1 315 768 4941
Email: info@riverhawk.com

Table of Contents

Section	Description	Page Number
1.0	Cautions and Safety Warnings	3
2.0	Scope and GE Part Number Cross Reference	4
3.0	Quick Start Guide	5
4.0	General Preparations	7
5.0	Tuning Cap and Tuning Plug Preparations	9
6.0	Installation in Load Coupling	10
7.0	Assembly Pattern in Load Coupling	17
8.0	Thread Locking on Tuning Cap	19
9.0	Tuning Cap & Plug Removal	20
10.0	Storage Instructions	26
11.0	Frequently Asked Questions	27
12.0	Revision History	29
Appendix A1	Tuning Cap and Tuning Plug Installation Datasheet	30



215 Clinton Road
 New Hartford, NY 13413
 Tel: +1 315 768 4855
 Fax: +1 315 768 4941
 Email: info@riverhawk.com

GE DRAWING NUMBER	REV
373A4063	B

1.0 Cautions and Safety Warnings

WARNING

Improper tool use and the failure to follow the correct procedures are the primary root causes of tool failures and personal injuries. A lack of training or experience can lead to incorrect hardware installation or incorrect tool use. Only trained operators with careful, deliberate actions should use this equipment.

CAUTION

This equipment requires moderate levels of torque for installation. Operators must exercise caution and wear the appropriate personal protective equipment when handling and operating the tuning caps, the tuning plugs, and the installation tool.

CAUTION

Riverhawk recommends that the installation tools be returned to Riverhawk for periodic inspections. Replacement of obsolete installation tools is recommended. Functional upgrades are also recommended. The Riverhawk Service Returns Coordinator should be notified 3-6 months prior to a planned outage to schedule an inspection service.

CAUTION

It is important to check the condition of the thread used to connect to the load coupling. Thread damage from previous abuse can lead to failure of the cap's mechanical locking feature.

CAUTION

Personal injury and equipment damage can occur if the proper health and safety codes and procedures are not followed. Contact the site's health and safety office to determine all applicable safety rules and regulations.

WARNING

The proper personal protective equipment must be worn at all times.

CAUTION

Before threading the tuning cap into the load coupling, carefully check the cleanliness of both the tuning cap's and the load coupling's threads. Apply a light coat of clean turbine oil to the tuning cap. This procedure will ease assembly before tightening. Do not use "Never Seize" on any surface or thread.

WARNING

Do not use lock-tite on any of the threads and do not stake any component of this assembly.



215 Clinton Road
New Hartford, NY 13413
Tel: +1 315 768 4855
Fax: +1 315 768 4941
Email: info@riverhawk.com

GE DRAWING NUMBER	REV
373A4063	B

CAUTION

Do not exceed the maximum torque marked on the installation tool. Excessive torque can damage the tuning cap and installation tool.

2.0 Scope

This document describes the procedure to be used to install the tuning caps and plugs supplied by the Riverhawk Company in the generator side flange of the 7FA.05 Load Coupling.

The GE part number configurations covered in this manual are listed in Sections 2.1 through 2.3 with differences as related to connective hardware defined. Listed also are the pertinent hardware drawings (MF-xxxx). These drawings as well as tooling drawings (MF-xxxx) form part of this manual.

2.1 Frame 7FA.05 Gas Turbine Load Coupling Tuning Cap

GE Part Number	Riverhawk P/N	GE VENDOC P/N
105T5274P001	MF-5958	GE 269B8759

The mechanical tooling used for installation and removal is Riverhawk MF-6011.

This hardware drawing depicts a single tuning cap used on the Frame 7FA.05 Gas Turbine Load Coupling.

2.2 Frame 7FA.05 Gas Turbine Load Coupling Tuning Plug

GE Part Number	Riverhawk P/N	GE VENDOC P/N
105T5274P002	MF-5959	GE 269B8760

The mechanical tooling used for installation and removal is Riverhawk MF-6011.

This hardware drawing depicts a single tuning plug used on the Frame 7FA.05 Gas Turbine Load Coupling.

2.3 Mechanical Tooling

GE Part Number	Riverhawk P/N	GE VENDOC P/N
105T5274P003	MF-6011	GE 269B8761



215 Clinton Road
 New Hartford, NY 13413
 Tel: +1 315 768 4855
 Fax: +1 315 768 4941
 Email: info@riverhawk.com

GE DRAWING NUMBER	REV
373A4063	B

3.0 Quick Checklist

The following checklist is intended as a summary of the steps needed to use the Riverhawk-supplied equipment. New personnel or those experienced personnel who have not used the Riverhawk equipment recently are encouraged to read the entire manual.

EQUIPMENT INSPECTION

- Clean load coupling's tuning holes and the immediate area around each hole.
- Inspect tuning holes for damage.
- Check for lock-tite or staking marks.

TUNING CAP PREPARATION

- Check the tuning cap for any visual damage. Thread damage can cause locking feature to malfunction.
- Clean used tuning caps with wire brush and petroleum-based solvent. Threads must be clean of grit and dirt.

TUNING PLUG PREPARATION

- Check the tuning plug for any visual damage.
- Clean used tuning plugs with wire brush and petroleum-based solvent.

INSTALLATION

- Thread tuning cap into load coupling's tuning hole on the generator side of the flange.
- Using the installation tool, torque the tuning cap to 30-35 ft·lbs [40.7-47.4 N·m].
- Move to next tuning hole until all holes on generator side of the flange are filled with caps.
- Insert the tuning plug into the holes required by the tuning plug pattern (see section 7.0) or the site's records.



215 Clinton Road
 New Hartford, NY 13413
 Tel: +1 315 768 4855
 Fax: +1 315 768 4941
 Email: info@riverhawk.com

GE DRAWING NUMBER	REV
373A4063	B

- Using the datasheet at the end of this manual, record the location of the tuning plugs.
- Thread the tuning cap into the load coupling's tuning hole on the flange's turbine side.
- Using the installation tool, torque the tuning cap to 30-35 ft·lbs [40.7-47.4 N·m].
- Move to the next tuning hole until all of the holes on flange's turbine side are filled with caps.
- On the generator side of the flange, re-torque the tuning cap to 30-35 ft·lbs [40.7-47.4 N·m].
- On the generator side of the flange, torque the tuning caps' set screws to 200-250 in·lbs [22.6-28.2 N·m].
- Move to the next tuning hole until all of the set screws on flange's generator side are torqued.
- On the turbine side of the flange, re-torque the tuning cap to 30-35 ft·lbs [40.7-47.4 N·m].
- On the turbine side of the flange, torque the tuning caps' set screws to 200-250 in·lbs [22.6-28.2 N·m].
- Move to the next tuning hole until all of the set screws on flange's turbine side are torqued.
- Using the datasheet at the end of this manual, record the locking of the tuning caps.

REMOVAL

- Record which tuning hole locations contain a tuning plug on the datasheet found at the end of this manual.
- Inspect the tuning plugs for lock-tite or staking.
- Loosen both of the set screws in all of the tuning caps. The set screws should be free to rotate.
- Place the installation tool on the tuning cap on the flange's turbine side.



215 Clinton Road
New Hartford, NY 13413
Tel: +1 315 768 4855
Fax: +1 315 768 4941
Email: info@riverhawk.com

GE DRAWING NUMBER	REV
373A4063	B

- Using a hand wrench, apply torque to loosen the tuning cap. **DO NOT EXCEED THE MAXIMUM TORQUE MARKED ON THE INSTALLATION TOOL. DO NOT USE ANY IMPACT TOOLS.**
- Place the installation tool on the tuning cap on the flange's generator side.
- Using a hand wrench, apply torque to loosen the tuning cap. **DO NOT EXCEED THE MAXIMUM TORQUE MARKED ON THE INSTALLATION TOOL. DO NOT USE ANY IMPACT TOOLS.**
- Move to the next tuning hole until all of the tuning caps have been loosened.
- Carefully remove and store the tuning caps and tuning plugs.

4.0 General Preparations

Read and understand all instructions before installing the tuning caps and plugs.

Operators should be trained or have previous experience using the tuning caps and plugs supplied by Riverhawk. Training will minimize the chance of improper use of the equipment.

The installation tooling should be inspected prior to use. Inspection guidelines are listed in the following sub-sections.

CAUTION

This equipment requires moderate levels of torque for installation. Operators must exercise caution and wear the appropriate personal protective equipment when handling and operating the tuning caps, the tuning plugs, and the installation tool.

CAUTION

Personal injury and equipment damage can occur if the proper health and safety codes and procedures are not followed. Contact the site's health and safety office to determine all applicable safety rules and regulations.

4.1 Machine Preparation

Clean the load coupling's tuning holes and the load coupling flange in the immediate area around each hole. Remove any built up dirt, oils, grease, never-seize compound, etc.



215 Clinton Road
New Hartford, NY 13413
Tel: +1 315 768 4855
Fax: +1 315 768 4941
Email: info@riverhawk.com

GE DRAWING NUMBER	REV
373A4063	B

Inspection at installation: Inspect the load coupling's tuning holes for any burrs, gouges, and other displaced metal. Inspect the threads for any damage. The best practice for inspection would include the use of a thread gage to check for thread damage.

Inspection at removal: Inspect the load coupling's tuning holes and the tuning caps for any burrs, gouges, and other displaced metal that may prevent the cap from turning. Application of penetrating oil between the load coupling's tuning hole and the cap could be advantageous.

It will be advantageous to remove as many nearby obstructions as possible from the flange area such as speed probes, shipping plates, conduit, etc. to obtain free access to both sides of the load coupling flange.

4.2 Tuning Caps and Plugs – Weight Balance

The tuning caps are supplied in component balanced sets. A tuning cap can be exchanged with another tuning cap in its set without affecting the overall balance of the equipment. Do not exchange a tuning cap from one set with another tuning cap from a different set. When shipped from Riverhawk, the tuning caps are not assigned to any specific hole in the load coupling flange; this is optional and can be done at the installation site. The set size is determined by the number of caps required by originating purchase order.

The tuning plugs are supplied in component balanced sets. A tuning plug can be exchanged with another tuning plug in its set without affecting the overall balance of the equipment. Do not exchange a tuning plug from one set with another tuning plug from a different set. When shipped from Riverhawk, the tuning plugs are not assigned to any specific hole in the load coupling flange; this is optional and can be done at the installation site. The set size is determined by the number of plugs required by originating purchase order.

A weight balance certification is supplied with each order. Store this certification in an appropriate location as it will be needed for the purchase of replacement equipment.

4.3 Care and Handling

When not in use, the tuning caps, tuning plugs, and installation tool shall be maintained in a clean environment and protected against corrosion, water, exposure to damaging chemicals, and wind-blown debris.

When in use, the tuning caps, tuning plugs, and installation tool shall be protected against corrosion, water, exposure to damaging chemicals, and wind-blown debris.

See section 10 for long term storage requirements.



215 Clinton Road
New Hartford, NY 13413
Tel: +1 315 768 4855
Fax: +1 315 768 4941
Email: info@riverhawk.com

GE DRAWING NUMBER	REV
373A4063	B

4.4 Hand Tools

Several hand wrenches and micrometers will be required to perform installation and measurement of the studs:

A set of Allen Wrenches

1" [25.4mm] Wrench

1" [25.4mm] Socket Wrench

Calibrated torque wrench with 1" [25.4mm] hex socket

4.5 Special Tools

Installation Tool: MF-6011 Installation Tool
(reference GE VENDOC 269B8761)

CAUTION

Riverhawk recommends that the installation tools be returned to Riverhawk for periodic inspections. Replacement of obsolete installation tools is recommended. Functional upgrades are also recommended. The Riverhawk Service Returns Coordinator should be notified 3-6 months prior to a planned outage to schedule an inspection service.

5.0 Tuning Cap and Tuning Plug Preparations

5.1 Tuning Cap Preparations

Check the cap for any visible damage. If there is any visible damage on a tuning cap, do not use the cap and contact the Riverhawk Company for a replacement cap. Please be prepared to supply site information, the turbine number, weight certification, and digital photographs for evaluation.

CAUTION

It is important to check the condition of the thread used to connect to the load coupling. Thread damage from previous abuse can lead to failure of the cap's mechanical locking feature.

5.1.1 Tuning Cap Cleaning - New Installations

For new installations, the caps should come sealed from the factory and will not require any cleaning.



215 Clinton Road
New Hartford, NY 13413
Tel: +1 315 768 4855
Fax: +1 315 768 4941
Email: info@riverhawk.com

GE DRAWING NUMBER	REV
373A4063	B

5.1.2 Tuning Cap Cleaning - Old Installations

Previously installed caps will require cleaning with a wire brush using a petroleum-based solvent to remove any foreign material on the external surfaces and threads.

The threads of each plug must be clean of grit and dirt before installation. This ensures the proper engagement of the mechanical locking feature.

5.2 Tuning Plug Preparation

Check the plug for any visible damage. If there is any visible damage, do not use the plug and contact the Riverhawk Company for a replacement plug. Please be prepared to supply site information, the turbine number, weight certification, and digital photographs for evaluation.

5.2.1 Tuning Plug - New Installations

For new installations, the plugs should come sealed from the factory and will not require any cleaning.

5.2.2 Tuning Plug - Old Installations

Previously installed plugs will require cleaning with a wire brush using a petroleum-based solvent to remove any foreign material on the external surfaces.

6.0 Installation in Load Coupling

WARNING

Do not use lock-tite on any of the threads and do not stake any component of this assembly.

CAUTION

Do not exceed the maximum torque marked on the installation tool. Excessive torque can damage the tuning cap and installation tool.

CAUTION

Personal injury and equipment damage can occur if the proper health and safety codes and procedures are not followed. Contact the site's health and safety office to determine all applicable safety rules and regulations.

WARNING

The proper personal protective equipment must be worn at all times.



215 Clinton Road
New Hartford, NY 13413
Tel: +1 315 768 4855
Fax: +1 315 768 4941
Email: info@riverhawk.com

GE DRAWING NUMBER	REV
373A4063	B

CAUTION

Before threading the tuning cap into the load coupling, carefully check the cleanliness of both the tuning cap's and the load coupling's threads. Apply a light coat of clean turbine oil to the tuning cap. This procedure will ease assembly before tightening. Do not use "Never Seize" on any surface or thread.

There are two options when installing the tuning caps and tuning plugs. Depending on the situation, either two tuning caps are installed in a tuning hole or two tuning caps and one tuning plug are installed. Section 7.0 describes a factory installation assembly pattern for the tuning caps and tuning plugs.

For a new installation, General Electric recommends using this initial pattern. Based on testing conducted at the site, it may be necessary to adjust this pattern. Consult with General Electric field support personnel for determining this pattern.

For existing installations, refer to the site's installation records to determine the pattern to use. Based on testing conducted at the site, it may be necessary to adjust this pattern. Consult with General Electric field support personnel for determining this pattern.

To install the tuning caps and tuning plugs, use the following instructions:

1. Inspect the load coupling's tuning hole for damage, debris, etc.
2. Inspect the tuning cap for damage, debris, etc. Apply a light coat of clean turbine oil to the tuning cap's thread to ease assembly into the tuning hole.
3. Thread the tuning cap into the load coupling's tuning hole on the generator (outboard) side of the load coupling's flange until the tuning cap contacts the bottom of the counterbore.



215 Clinton Road
New Hartford, NY 13413
Tel: +1 315 768 4855
Fax: +1 315 768 4941
Email: info@riverhawk.com

GE DRAWING NUMBER	REV
373A4063	B

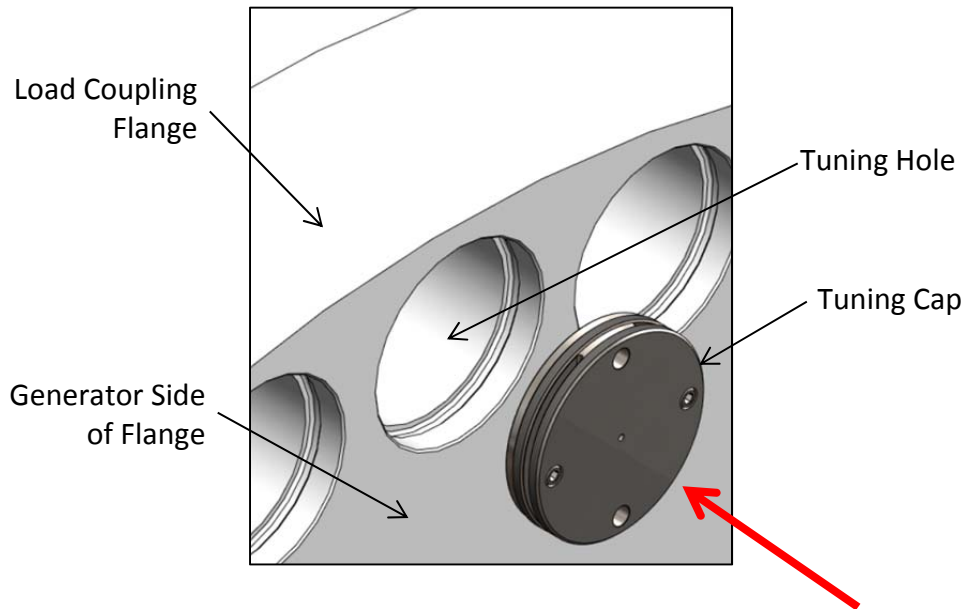

Figure 6A – Inserting Tuning Cap

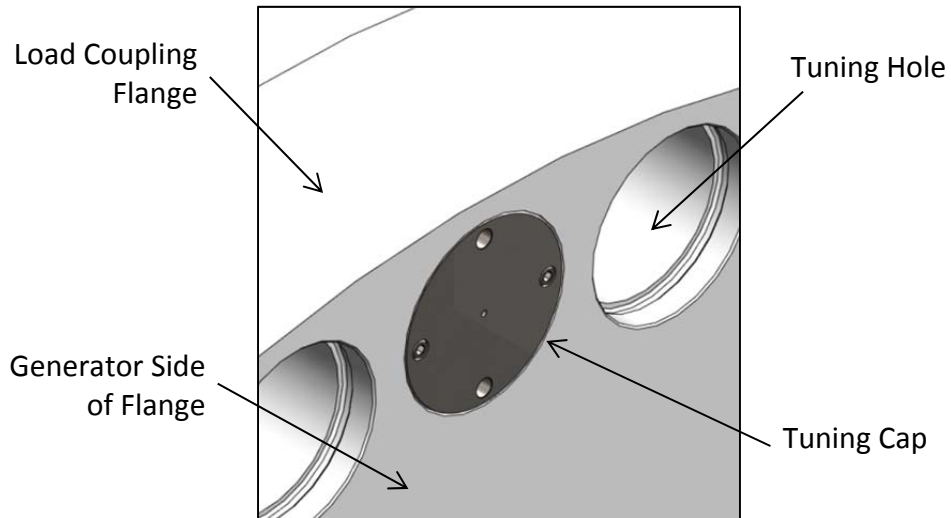

Figure 6B – Inserted Tuning Cap

4. Place the installation tool onto the tuning cap. The two dowel pins on the installation tool are inserted into the two holes in the tuning cap.



215 Clinton Road
 New Hartford, NY 13413
 Tel: +1 315 768 4855
 Fax: +1 315 768 4941
 Email: info@riverhawk.com

GE DRAWING NUMBER	REV
373A4063	B

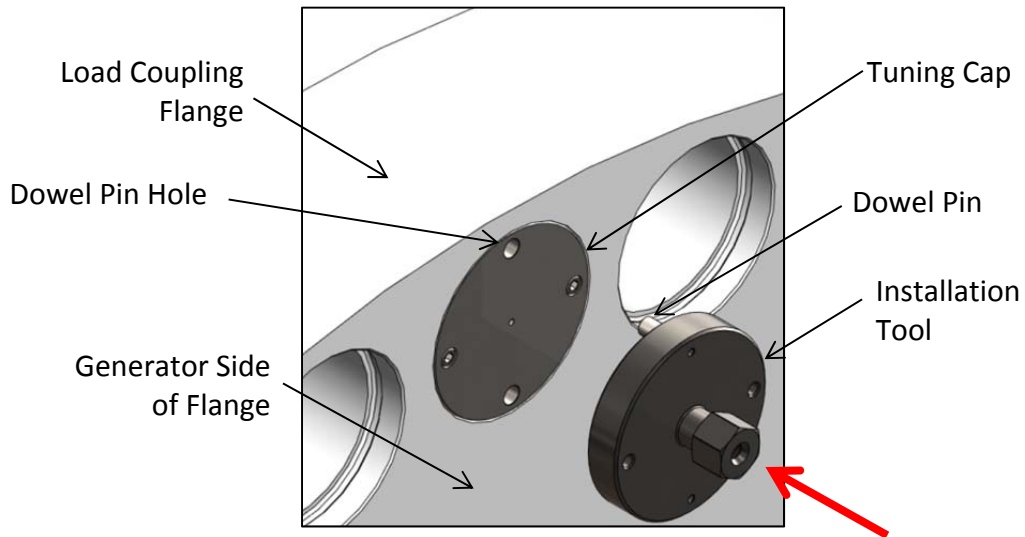

Figure 6C – Attaching Installation Tool

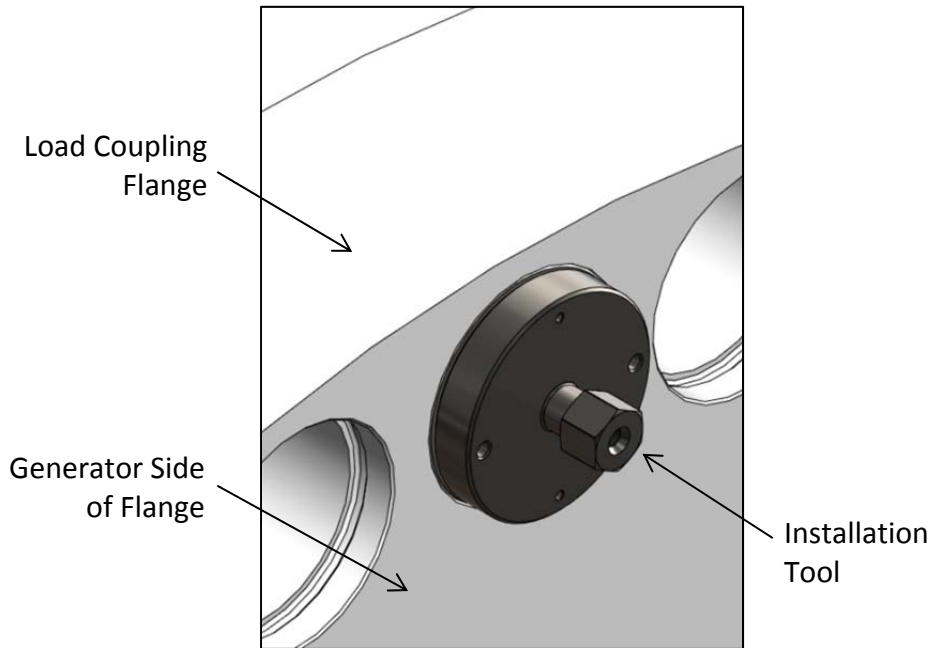

Figure 6D – Attached Installation Tool

5. Using a torque wrench, apply 30-35 ft·lbs [40.7-47.4 N·m] of torque to tighten the tuning cap.
6. Move to the next tuning hole and repeat steps 2 thru 5. Continue until all of the tuning holes on the generator (outboard) side of the load coupling are filled.



215 Clinton Road
 New Hartford, NY 13413
 Tel: +1 315 768 4855
 Fax: +1 315 768 4941
 Email: info@riverhawk.com

GE DRAWING NUMBER	REV
373A4063	B

7. If the tuning hole is to contain tuning plug (see section 7.0), continue to step 8. Otherwise, continue to step 11.
8. Inspect the tuning plug for damage, debris, etc. Apply a light coat of clean turbine oil to the tuning plug's outer diameter to ease assembly into the tuning hole.
9. Insert the tuning plug into the load coupling's tuning hole from the turbine (inboard) side of the load coupling's flange until the tuning plug contacts the tuning cap. To ease assembly, rotate the plug as it is inserted into the tuning hole. Using the datasheet at the end of this manual, record the location of the inserted tuning plugs.

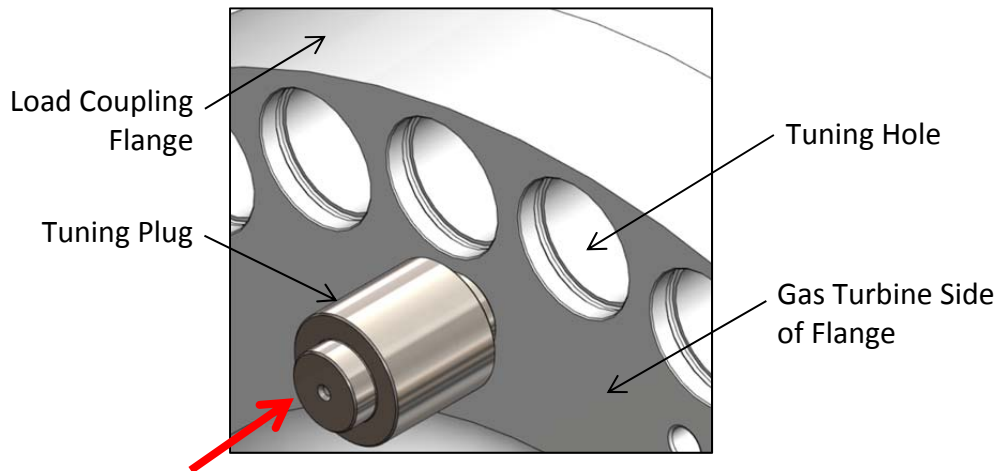

Figure 6E – Inserting Tuning Plug

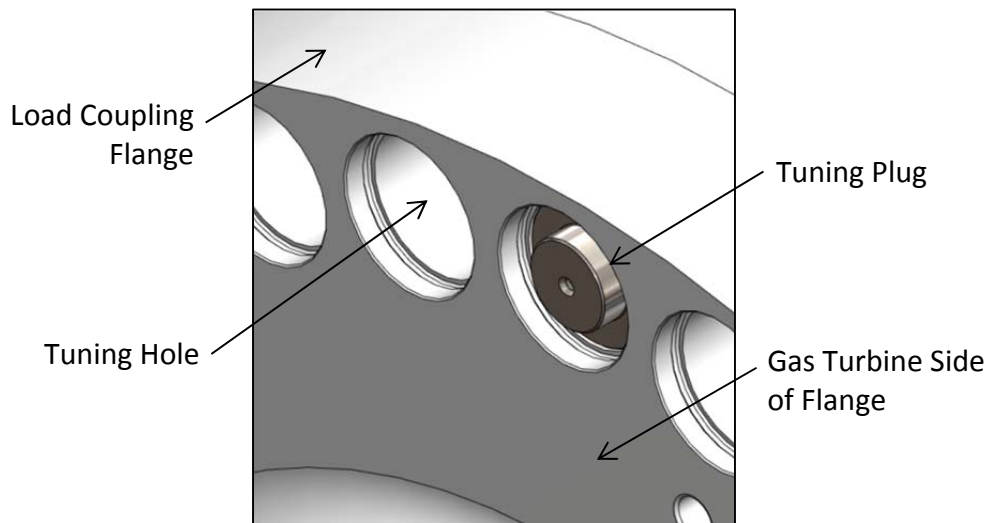

Figure 6F – Inserted Tuning Plug



215 Clinton Road
 New Hartford, NY 13413
 Tel: +1 315 768 4855
 Fax: +1 315 768 4941
 Email: info@riverhawk.com

GE DRAWING NUMBER	REV
373A4063	B

10. Move to the next tuning hole in the tuning plug installation sequence and repeat steps 8 thru 10.
11. Inspect the tuning cap for damage, debris, etc. Apply a light coat of clean turbine oil to the tuning cap's thread to ease assembly into the tuning hole.

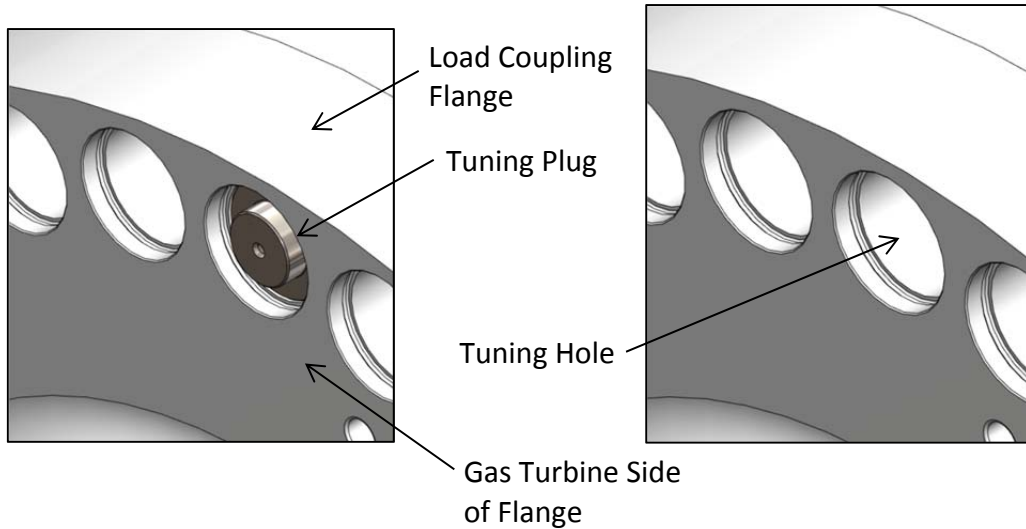

12. Thread the tuning cap into the load coupling's tuning hole on the turbine (inboard) side of the load coupling's flange until the tuning cap contacts either the tuning plug or the bottom of the counterbore.

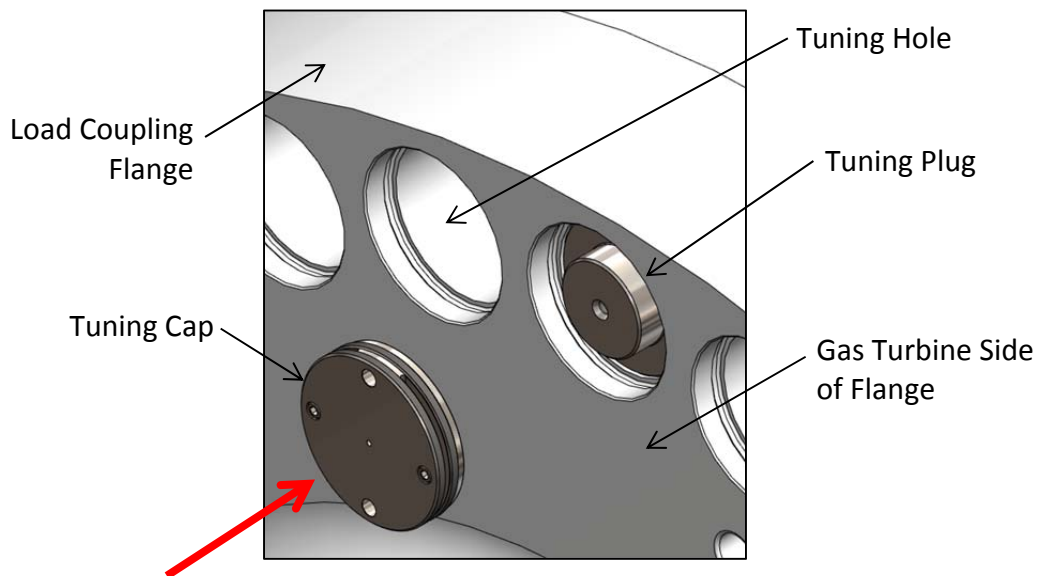

215 Clinton Road
 New Hartford, NY 13413
 Tel: +1 315 768 4855
 Fax: +1 315 768 4941
 Email: info@riverhawk.com

GE DRAWING NUMBER	REV
373A4063	B

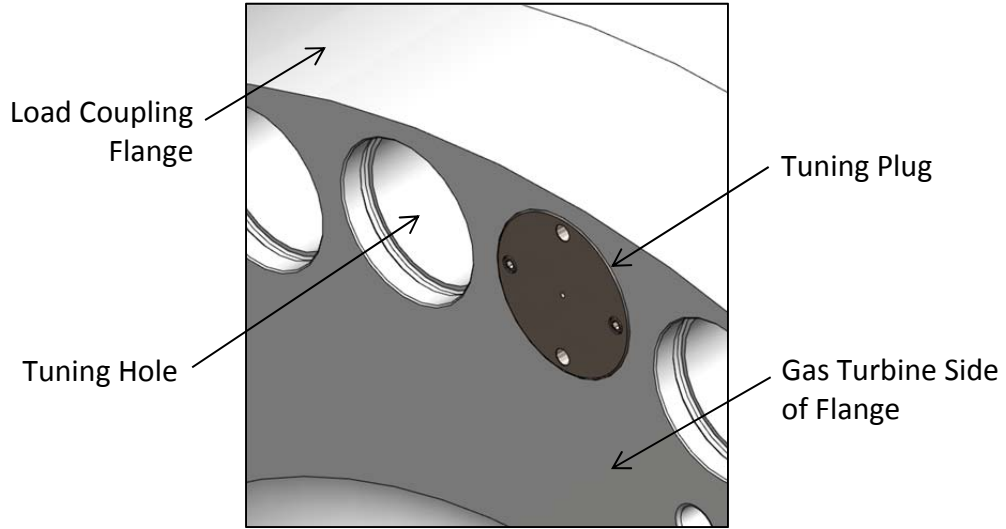

Figure 6J – Inserted Tuning Cap

13. Place the installation tool onto the tuning cap. The two dowel pins on the installation tool are inserted into the two holes in the tuning cap.

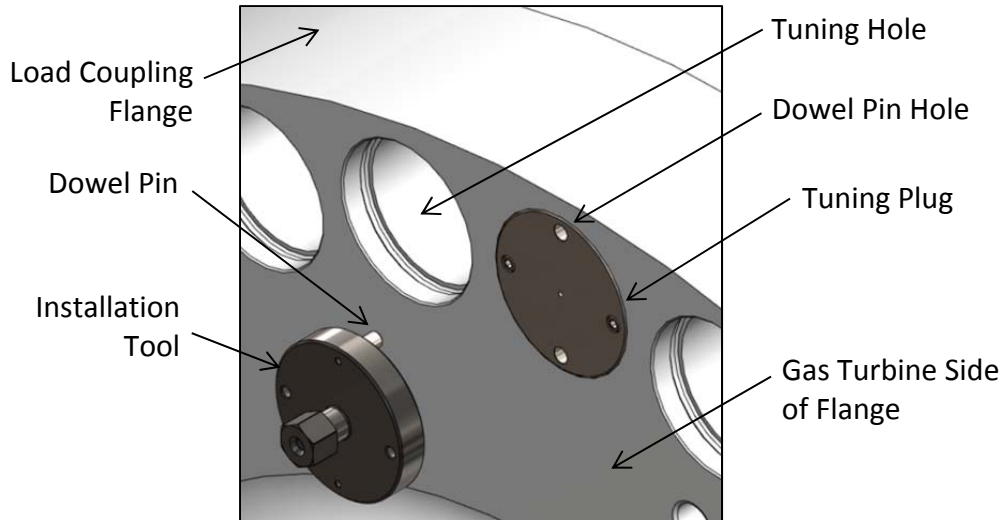

Figure 6K – Inserted Tuning Cap



215 Clinton Road
 New Hartford, NY 13413
 Tel: +1 315 768 4855
 Fax: +1 315 768 4941
 Email: info@riverhawk.com

GE DRAWING NUMBER	REV
373A4063	B

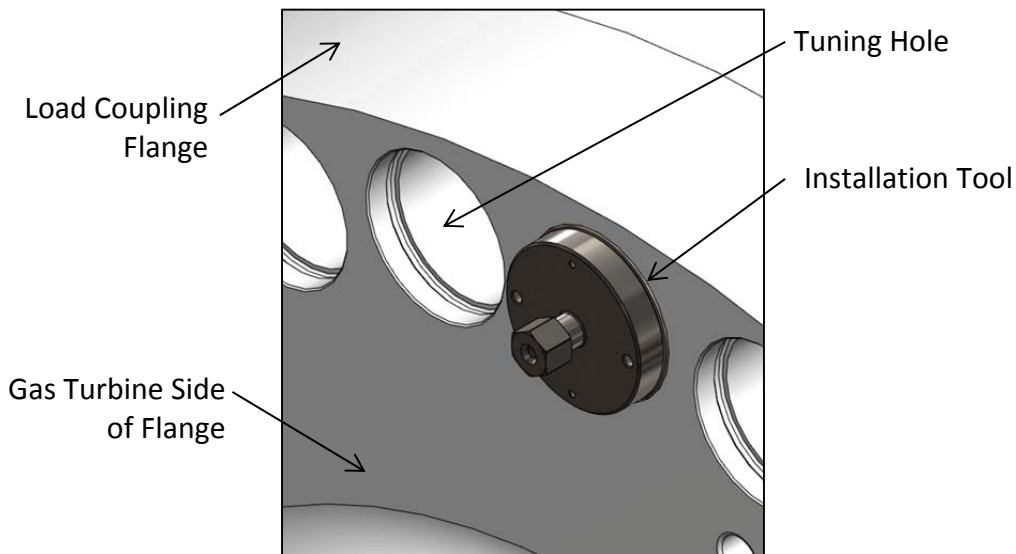

Figure 6L – Inserted Tuning Cap

14. Using a torque wrench, apply 30-35 ft-lbs [40.7-47.4 N·m] of torque to tighten the tuning cap.
15. Move to the next tuning hole and repeat steps 11 thru 14. Continue until all of the tuning holes are filled.
16. Using the datasheet provided at the end of this manual, record the location of the tuning holes with installed tuning plugs. Record any other installation notes here as well such as modifications done to any parts involved.

7.0 Assembly Pattern in Load Coupling

The assembly instructions for installing the tuning caps and plugs are located in the preceding section.

For old installations, Riverhawk has added a datasheet at the end of this manual to track which holes contain tuning plugs and which holes only contain tuning caps. Prior to removal of the tuning caps and tuning plugs, fill out this datasheet to record the tuning plug locations. The tuning caps have a center hole to allow the passage of a small probe to determine if a hole contains a tuning plug. Create a new datasheet upon installation to indicate any changes. Keep the datasheet with the turbine’s records.

For new installations, GE Power and Water design engineering requires the following initial pattern of tuning caps and tuning plugs.



215 Clinton Road
 New Hartford, NY 13413
 Tel: +1 315 768 4855
 Fax: +1 315 768 4941
 Email: info@riverhawk.com

GE DRAWING NUMBER	REV
373A4063	B

Holes L thru P

Tuning Assembly consists of:

- 2 tuning caps
- **NO** tuning plug

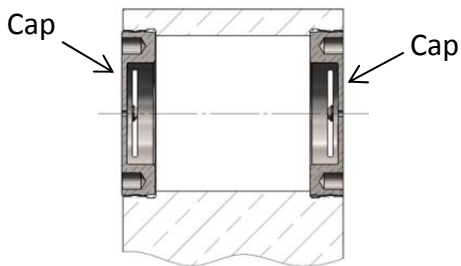

Figure 7A –Tuning Assembly (no plug)

Holes A thru K

Tuning Assembly consists of:

- 2 tuning caps
- **1** tuning plug

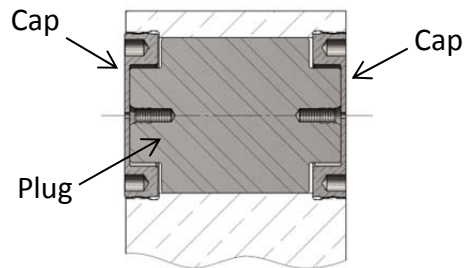

Figure 7B –Tuning Assembly (with plug)

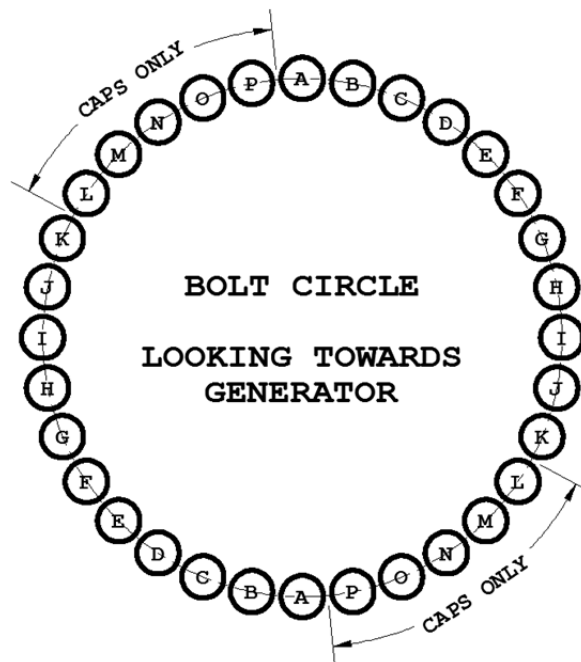

Figure 7C – Tuning Plug Factory Installation Pattern

Tuning Plugs must be installed in even numbers and in diametrically opposite holes to avoid balance issues. The locations and number of the tuning plugs can be adjusted as required to achieve the desired vibration frequency response. Consult with General Electric field support personnel for determining this pattern. Please note any deviations from this initial pattern in the turbine's records.



215 Clinton Road
 New Hartford, NY 13413
 Tel: +1 315 768 4855
 Fax: +1 315 768 4941
 Email: info@riverhawk.com

GE DRAWING NUMBER	REV
373A4063	B

8.0 Thread Locking on Tuning Cap

WARNING

Do not use lock-tite on any of the threads. Do not stake the tuning plug to the tuning hole. Do not stake the tuning caps' set screws in place.

CAUTION

Do not exceed the maximum torque marked on the installation tool. Excessive torque can damage the tuning cap and installation tool.

CAUTION

Personal injury and equipment damage can occur if the proper health and safety codes and procedures are not followed. Contact the site's health and safety office to determine all applicable safety rules and regulations.

WARNING

The proper personal protective equipment must be worn at all times.

To lock the tuning caps in place, use the following instructions:

1. Starting on the generator (outboard) side of the load coupling's flange, verify the tightness of the tuning cap by torquing the tuning caps with the torque wrench to 30-35 ft·lbs [40.7-47.4 N·m].
2. Using an Allen wrench, tighten the two set screws in the tuning cap to 200-250 in·lbs [22.6-28.2 N·m] of torque.

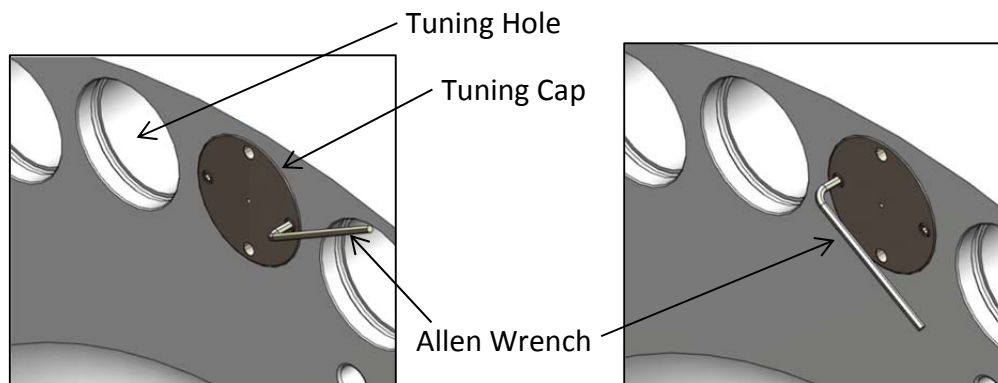

Figure 8A – Using Allen wrench to tighten set screw

Figure 8B – Using Allen wrench to tighten set screw

3. Move to the next tuning hole and repeat steps 1 and 2. Continue until all of the tuning holes on the generator (outboard) side of the load coupling are locked in place.



215 Clinton Road
New Hartford, NY 13413
Tel: +1 315 768 4855
Fax: +1 315 768 4941
Email: info@riverhawk.com

GE DRAWING NUMBER	REV
373A4063	B

4. Starting on the turbine (inboard) side of the load coupling's flange, verify the tightness of the tuning cap by torquing the tuning caps with the torque wrench to 30-35 ft·lbs [40.7-47.4 N·m].
5. Using an Allen wrench, tighten the two set screws in the tuning cap to 200-250 in·lbs [22.6-28.2 N·m] of torque.
6. Move to the next tuning hole and repeat steps 4 and 5. Continue until all of the tuning holes on the turbine (inboard) side of the load coupling are locking in place.
7. Using the datasheet provided at the end of this manual, record the locking of the tuning caps and any installation notes.

9.0 Tuning Cap and Plug Removal

Riverhawk has added a datasheet at the end of this manual to track which holes contain tuning plugs and which holes only contain tuning caps. Prior to removal of the tuning caps and tuning plugs, fill out this datasheet to record the tuning plug locations. The tuning caps have a center hole to allow the passage of a small probe to determine if a hole contains a tuning plug. Keep the datasheet with the turbine's records.

CAUTION

Personal injury and equipment damage can occur if the proper health and safety codes and procedures are not followed. Contact the site's health and safety office to determine all applicable safety rules and regulations.

WARNING

The proper personal protective equipment must be worn at all times.

CAUTION

Do not exceed the maximum torque marked on the installation tool. Excessive torque can damage the tuning cap and installation tool.

To remove the tuning caps and plugs, use the following instructions:

1. Record the which tuning hole locations contain a tuning plug on a datasheet found at the end of this manual. The tuning caps have a small center hole to allow a probe access to the tuning plugs.
2. Examine the tuning plugs for evidence of lock-tite or staking. If the parts have lock-tite or are staked, contact the Riverhawk Company for assistance.



215 Clinton Road
New Hartford, NY 13413
Tel: +1 315 768 4855
Fax: +1 315 768 4941
Email: info@riverhawk.com

GE DRAWING NUMBER	REV
373A4063	B

- Loosen, but do not remove the two set screws on each tuning cap. The set screws should be free to rotate. Tuning caps are located on both sides of the load coupling flange.

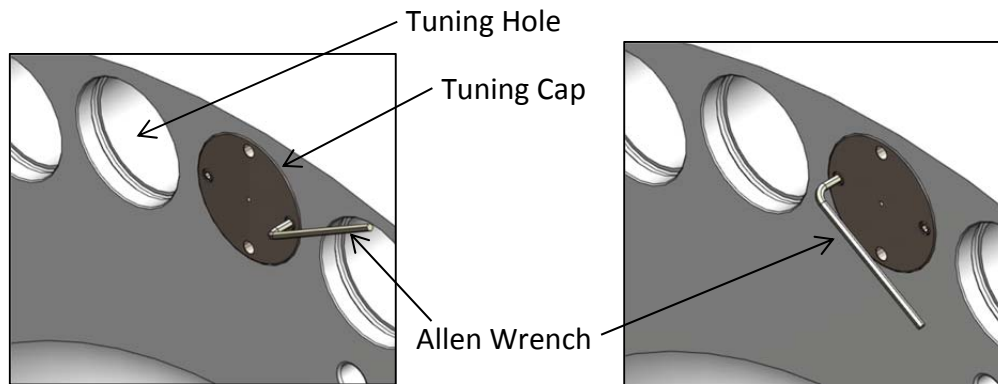

Figure 9A – Using Allen wrench to loosen set screw

Figure 9B – Using Allen wrench to loosen set screw

- Move to the next tuning hole and repeat step 3 until all of the tuning caps are unlocked.
- Place the installation tool onto the tuning cap on the turbine (inboard) side of the load coupling. The two dowel pins on the installation tool are inserted into the two holes in the tuning cap.

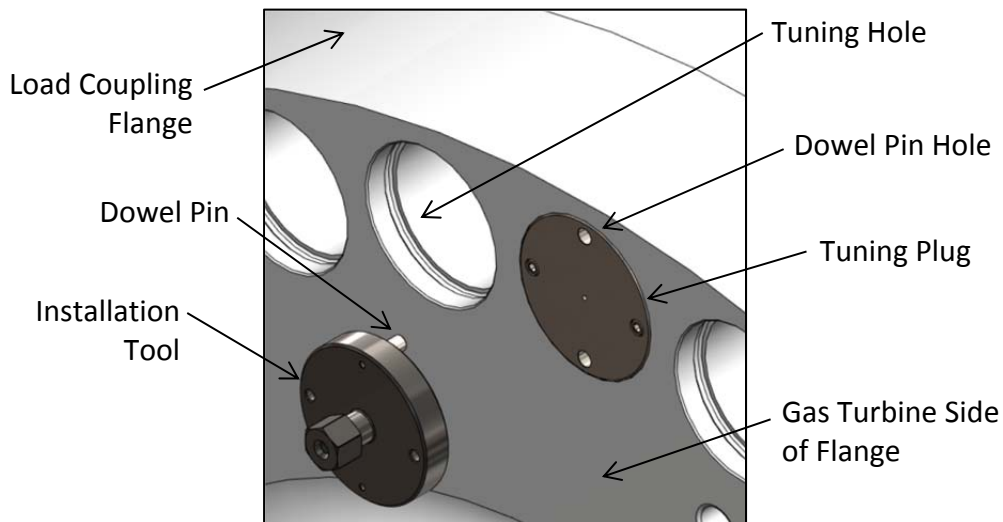

Figure 9C – Removing Tuning Cap



215 Clinton Road
 New Hartford, NY 13413
 Tel: +1 315 768 4855
 Fax: +1 315 768 4941
 Email: info@riverhawk.com

GE DRAWING NUMBER	REV
373A4063	B

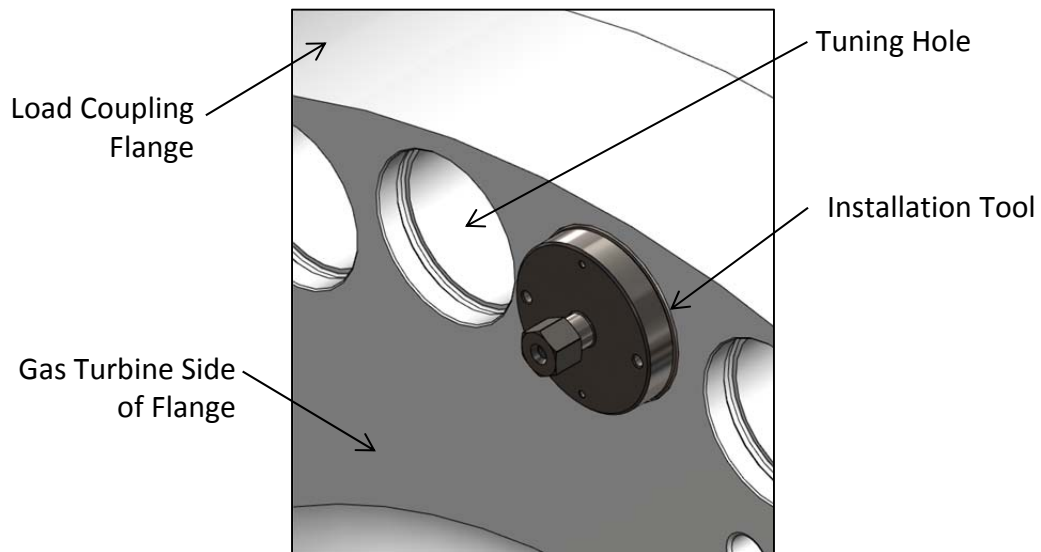

Figure 9D – Removing Tuning Cap

6. Using a hand wrench, apply torque to loosen the tuning cap. **DO NOT EXCEED THE MAXIMUM TORQUE MARKED ON THE INSTALLATION TOOL. DO NOT USE ANY IMPACT TOOLS.**
7. Place the installation tool onto the tuning cap on the generator (outboard) side of the load coupling. The two dowel pins on the installation tool are inserted into the two holes in the tuning cap.

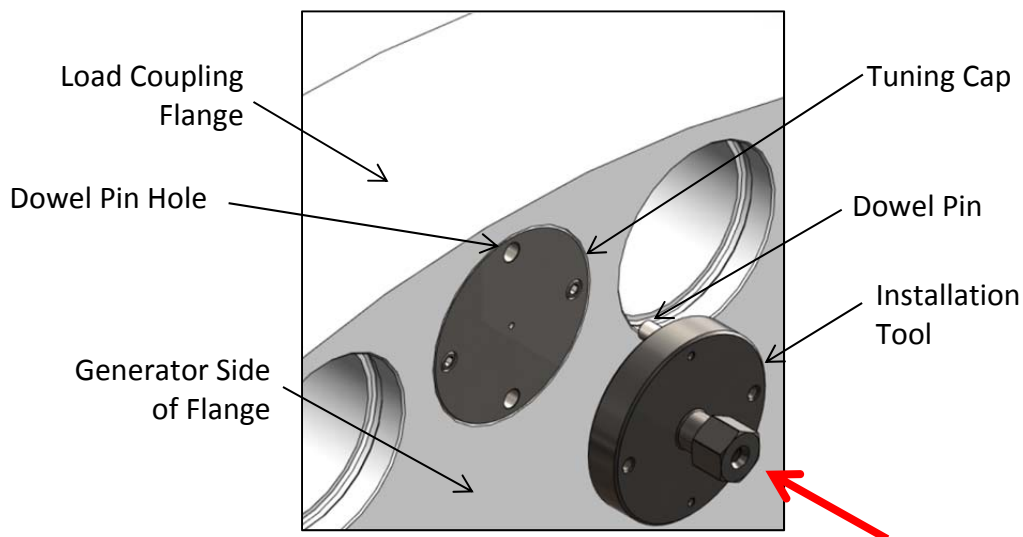

Figure 9E – Removing Tuning Cap



215 Clinton Road
 New Hartford, NY 13413
 Tel: +1 315 768 4855
 Fax: +1 315 768 4941
 Email: info@riverhawk.com

GE DRAWING NUMBER	REV
373A4063	B

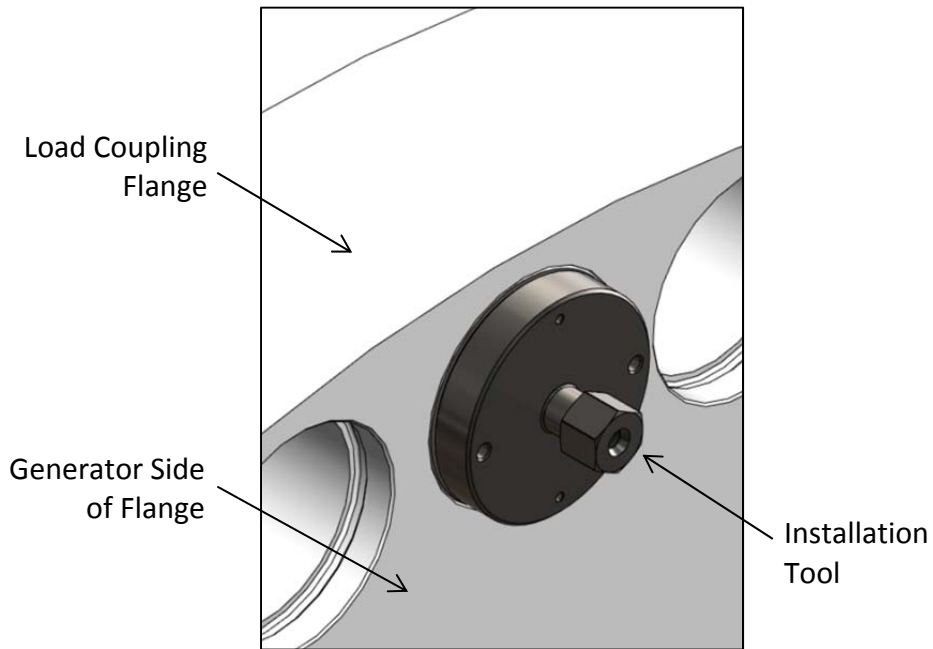

Figure 9F – Removing Tuning Cap

8. Using a hand wrench, apply torque to loosen the tuning cap. **DO NOT EXCEED THE MAXIMUM TORQUE MARKED ON THE INSTALLATION TOOL. DO NOT USE ANY IMPACT TOOLS.**
9. Move to the next tuning hole and repeat steps 5 thru 8 until all of the tuning caps are loose.
10. Remove the tuning caps from the tuning hole. If present, slide the tuning plug out of the tuning hole.



215 Clinton Road
New Hartford, NY 13413
Tel: +1 315 768 4855
Fax: +1 315 768 4941
Email: info@riverhawk.com

GE DRAWING NUMBER	REV
373A4063	B

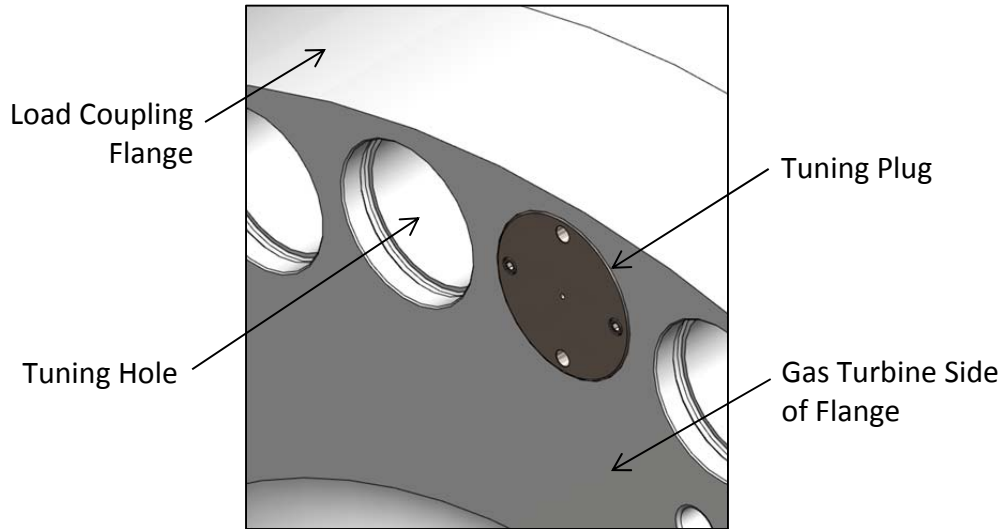

Figure 9G – Removing Tuning Cap

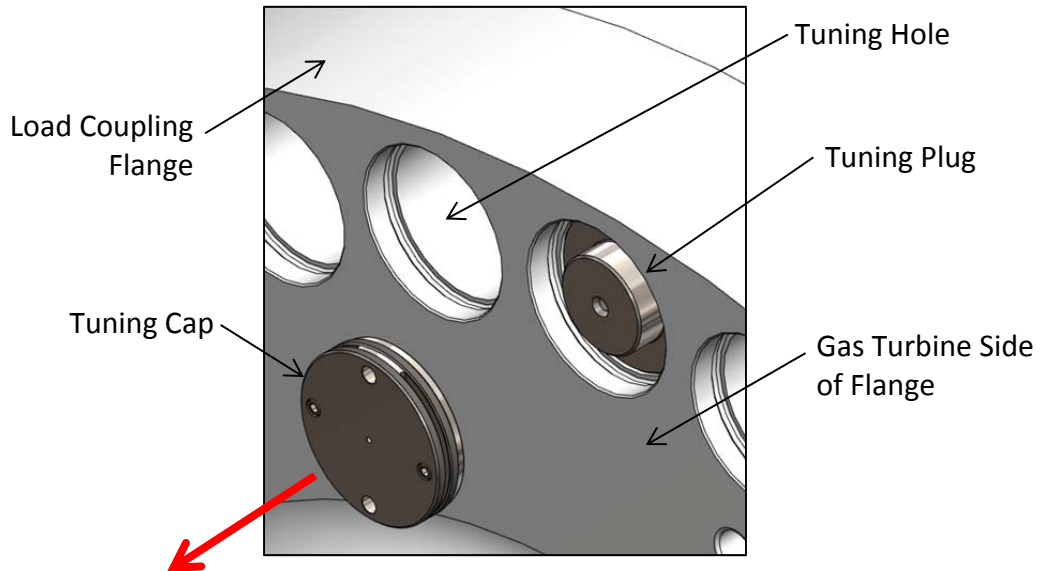

Figure 9H – Removing Tuning Cap



215 Clinton Road
New Hartford, NY 13413
Tel: +1 315 768 4855
Fax: +1 315 768 4941
Email: info@riverhawk.com

GE DRAWING NUMBER	REV
373A4063	B

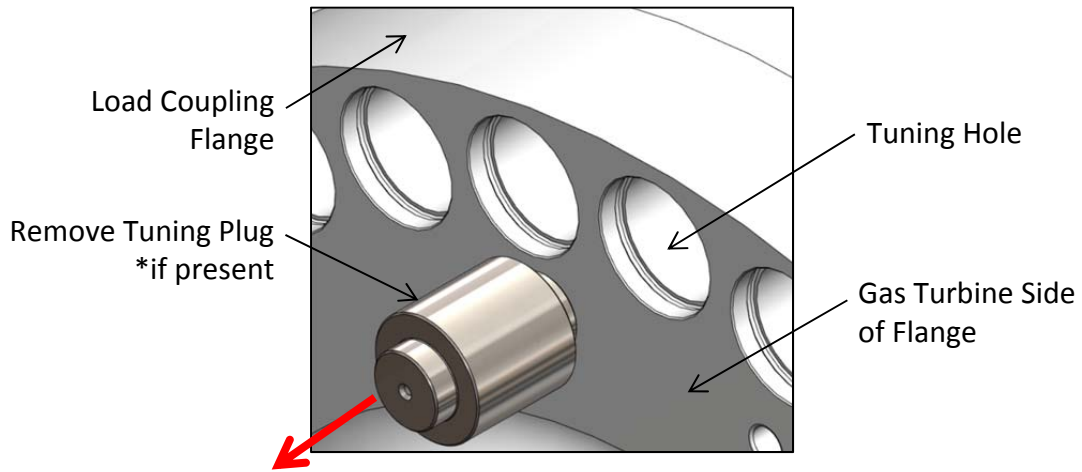

Figure 9J – Removing Tuning Plug

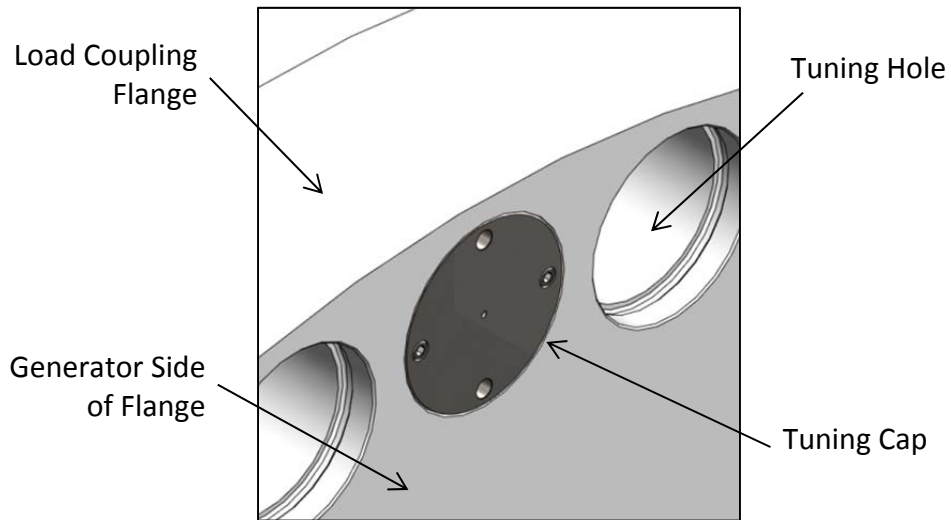

Figure 9K – Removing Tuning Cap



215 Clinton Road
New Hartford, NY 13413
Tel: +1 315 768 4855
Fax: +1 315 768 4941
Email: info@riverhawk.com

GE DRAWING NUMBER	REV
373A4063	B

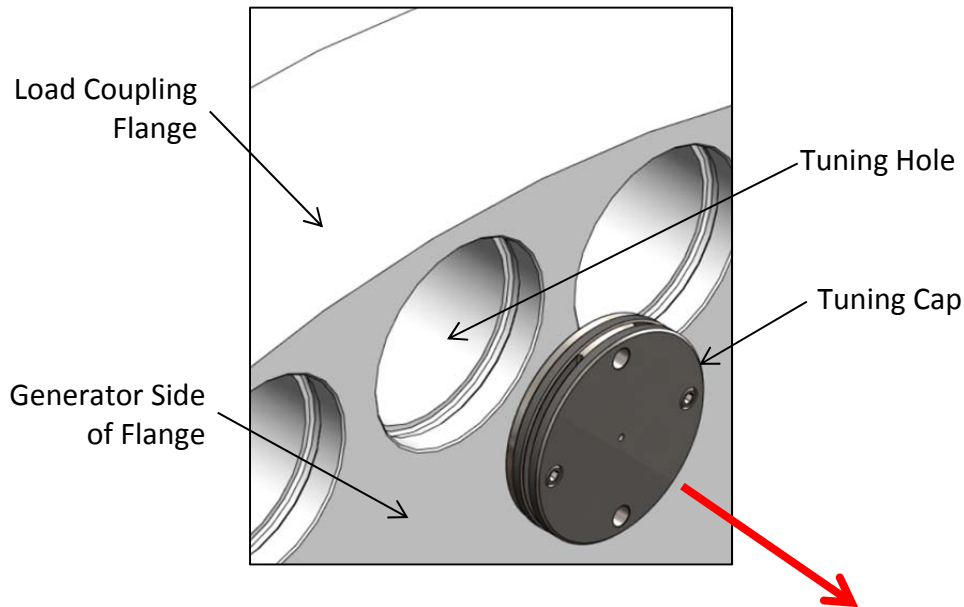

Figure 9L – Removing Tuning Cap

11. Move to the next tuning hole and repeat step 10. Continue until all of the tuning holes are empty.

10.0 Storage Instructions

Follow these directions to properly store your tuning caps, tuning plugs, and installation tool for long term storage and shipment.

10.1 Tuning Caps

Examine the parts for any visual damage. If there is any visible damage, do not store the part and contact the Riverhawk Company for a replacement. Please be prepared to supply site information, the turbine number, weight certification, and digital photographs for evaluation.

CAUTION

It is important to check the condition of the thread used to connect to the load coupling. Thread damage from previous abuse can lead to failure of the cap's mechanical locking feature.

Clean the tuning caps with a wire brush using a petroleum-based solvent to remove any foreign material on the external surfaces and threads.

Apply a light coat of clean turbine oil to the parts and wrap the parts in VCI-impregnated paper for placement in the long-term storage box. Do not wrap the parts in plastic.



215 Clinton Road
 New Hartford, NY 13413
 Tel: +1 315 768 4855
 Fax: +1 315 768 4941
 Email: info@riverhawk.com

GE DRAWING NUMBER	REV
373A4063	B

10.2 Tuning Plugs

Examine the parts for any visual damage. If there is any visible damage, do not store the part and contact the Riverhawk Company for a replacement. Please be prepared to supply site information, the turbine number, weight certification, and digital photographs for evaluation.

Clean the tuning plugs with a wire brush using a petroleum-based solvent to remove any foreign material on the external surfaces.

Apply a light coat of clean turbine oil to the parts and wrap the parts in VCI-impregnated paper for placement in the long-term storage box. Do not wrap the parts in plastic.

10.3 Installation Tools

Examine the parts for any visual damage. If there is any visible damage, do not store the part and contact the Riverhawk Company for a replacement. Please be prepared to supply site information, the turbine number, weight certification, and digital photographs for evaluation.

Clean the installation tool with a wire brush using a petroleum-based solvent to remove any foreign material on the external surfaces.

Apply a light coat of clean turbine oil to the installation tool and wrap the installation tool in VCI-impregnated paper for placement in the long-term storage box. Do not wrap the installation tool in plastic

10.4 Store shipping container

Secure the tuning caps, tuning plugs, and installation tool in the original shipping containers using the supplied wood braces.

Seal the original shipping container and store under shelter and protected from moisture, sand, and grit.

11.0 Frequently Asked Questions

This section contains some frequently asked questions and problems. If the steps listed here do not solve your problem, contact the Riverhawk Company thru our website, email, or phone call.



215 Clinton Road
New Hartford, NY 13413
Tel: +1 315 768 4855
Fax: +1 315 768 4941
Email: info@riverhawk.com

GE DRAWING NUMBER	REV
373A4063	B

Q: A tuning cap has damaged threads. Can I continue to use the tuning cap?

A: No. The damaged thread may have compromised the strength of the thread locking feature. Riverhawk can supply a replacement tuning cap based on the initial weight certification supplied with the hardware set (see section 4.2).

If a tuning cap must be left in place, paint the tuning cap with a generous amount of indelible, bright-colored paint. Notify the appropriate GE Safety and Field Service personnel. Note the location of the damaged tuning cap in the services notes for the machine.

Q: The tuning cap is turning in the hole while I am trying to loosen the set screws. Is there a way to hold the tuning cap to stop it from rotating?

A: Yes. The installation tool comes with two access holes located above the set screws. Place the installation tool on the tuning cap and insert an Allen wrench thru the access hole.

Q: The tuning plug is stuck in the hole while I am trying to remove it. What else can I do to help remove the plug from the hole?

A: Insert penetrating oil in between the tuning plug and the hole. The plug also has a threaded hole on its end that can be used for additional leverage. Exercise caution to prevent the threaded hole from stripping out.

Q: Can I attach a lanyard to the installation tool to prevent an accidental tool drop?

A: Yes. The installation tool comes with a threaded hole located in the middle of its hex drive. A fastener and lanyard can be attached to this threaded hole.

Q: The tuning cap or plug is staked in place. How can I remove it?

A: Remove the raised material from around staked area. Take care to remove only the material necessary to free the tuning cap or plug. Contact GE Field Service personnel for assistance to determine the next step. Any thread damage that results from freeing the parts must be evaluated.



215 Clinton Road
New Hartford, NY 13413
Tel: +1 315 768 4855
Fax: +1 315 768 4941
Email: info@riverhawk.com

GE DRAWING NUMBER	REV
373A4063	B

Q: Some of the set screws used in the tuning caps are missing. Can I replace these with normal set screw?

A: No. The set screws that Riverhawk Company supplies have a special lubricating coating. The use of other set screws can cause the locking feature to malfunction. Replacement set screws are readily available from Riverhawk Company.

Q: The tuning cap is stuck in the hole, but it is not staked in place.

A: Apply penetrating oil to the tuning cap's threads. Apply more torque to the installation tool, but do not exceed the torque rating marked on the installation tool.

12.0 Revision History

Revision Letter	Effective Date	Description
B	Aug 23, 2013	Customer requested change to Figure 7C and Appendix A1. Hole numbering sequence changed to match hole lettering sequence from the customer's manufacturing drawing of the load coupling
A	Mar 21, 2013	Customer recommend changes to section 3.0 installation steps 3, 4, 8, 9, and 12 and to section 7.0 to add plug installations in diametrically opposite pairs.
-	Mar 15, 2013	Released



215 Clinton Road
 New Hartford, NY 13413
 Tel: +1 315 768 4855
 Fax: +1 315 768 4941
 Email: info@riverhawk.com

GE DRAWING NUMBER	REV
373A4063	B

Appendix A1

**RECORD SHEET FOR THE LOAD COUPLING'S
TUNING CAPS AND PLUGS**

TURBINE NUMBER:

DATE:

TECHNICIAN:

SUPERVISOR:

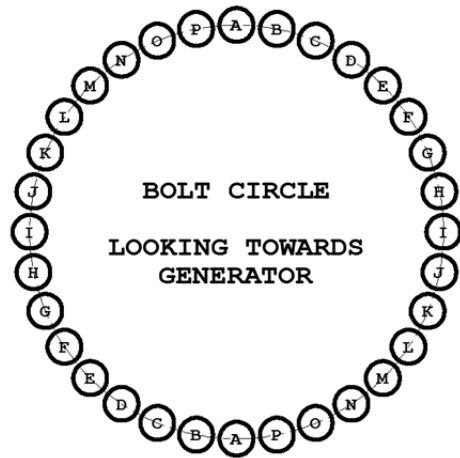

HOLE NUMBER	GT SIDE CAP - SET SCREWS LOCKED	PLUG INSIDE TUNING HOLE	GEN SIDE CAP - SET SCREWS LOCKED
A	<input type="checkbox"/>	<input type="checkbox"/>	<input type="checkbox"/>
B	<input type="checkbox"/>	<input type="checkbox"/>	<input type="checkbox"/>
C	<input type="checkbox"/>	<input type="checkbox"/>	<input type="checkbox"/>
D	<input type="checkbox"/>	<input type="checkbox"/>	<input type="checkbox"/>
E	<input type="checkbox"/>	<input type="checkbox"/>	<input type="checkbox"/>
F	<input type="checkbox"/>	<input type="checkbox"/>	<input type="checkbox"/>
G	<input type="checkbox"/>	<input type="checkbox"/>	<input type="checkbox"/>
H	<input type="checkbox"/>	<input type="checkbox"/>	<input type="checkbox"/>
I	<input type="checkbox"/>	<input type="checkbox"/>	<input type="checkbox"/>
J	<input type="checkbox"/>	<input type="checkbox"/>	<input type="checkbox"/>
K	<input type="checkbox"/>	<input type="checkbox"/>	<input type="checkbox"/>
L	<input type="checkbox"/>	<input type="checkbox"/>	<input type="checkbox"/>
M	<input type="checkbox"/>	<input type="checkbox"/>	<input type="checkbox"/>
N	<input type="checkbox"/>	<input type="checkbox"/>	<input type="checkbox"/>
O	<input type="checkbox"/>	<input type="checkbox"/>	<input type="checkbox"/>
P	<input type="checkbox"/>	<input type="checkbox"/>	<input type="checkbox"/>

HOLE NUMBER	GT SIDE CAP - SET SCREWS LOCKED	PLUG INSIDE TUNING HOLE	GEN SIDE CAP - SET SCREWS LOCKED
A	<input type="checkbox"/>	<input type="checkbox"/>	<input type="checkbox"/>
B	<input type="checkbox"/>	<input type="checkbox"/>	<input type="checkbox"/>
C	<input type="checkbox"/>	<input type="checkbox"/>	<input type="checkbox"/>
D	<input type="checkbox"/>	<input type="checkbox"/>	<input type="checkbox"/>
E	<input type="checkbox"/>	<input type="checkbox"/>	<input type="checkbox"/>
F	<input type="checkbox"/>	<input type="checkbox"/>	<input type="checkbox"/>
G	<input type="checkbox"/>	<input type="checkbox"/>	<input type="checkbox"/>
H	<input type="checkbox"/>	<input type="checkbox"/>	<input type="checkbox"/>
I	<input type="checkbox"/>	<input type="checkbox"/>	<input type="checkbox"/>
J	<input type="checkbox"/>	<input type="checkbox"/>	<input type="checkbox"/>
K	<input type="checkbox"/>	<input type="checkbox"/>	<input type="checkbox"/>
L	<input type="checkbox"/>	<input type="checkbox"/>	<input type="checkbox"/>
M	<input type="checkbox"/>	<input type="checkbox"/>	<input type="checkbox"/>
N	<input type="checkbox"/>	<input type="checkbox"/>	<input type="checkbox"/>
O	<input type="checkbox"/>	<input type="checkbox"/>	<input type="checkbox"/>
P	<input type="checkbox"/>	<input type="checkbox"/>	<input type="checkbox"/>



215 Clinton Road
New Hartford, NY 13413
Tel: +1 315 768 4855
Fax: +1 315 768 4941
Email: info@riverhawk.com

GE DRAWING NUMBER	REV
373A4063	B