

HYDRAULIC PUSHER PISTON/CYLINDERS



Riverhawk has developed a full line of hydraulic pusher piston/cylinders to accommodate any shaft end and coupling hub configuration. Our pusher piston/cylinders are specifically designed for each application to accommodate your shaft end with full pull-up stroke capability to meet your specifications.

They are made from hardened alloy steel. The pushers are delivered completely assembled with all seals

and fittings to match your installation equipment and pressure tested to ensure against leaks at installation.

- Designed and constructed to match any machine shaft end/coupling hub.
- Full stroke accommodates full pull-up specification.
- Hardened Alloy Steel for durability/repeated use.

- Assemblies are pressure tested to ensure against leaks at installation.
- Delivered completely assembled with necessary seals and fittings.



HYDRAULIC PUSHER PISTON/CYLINDERS

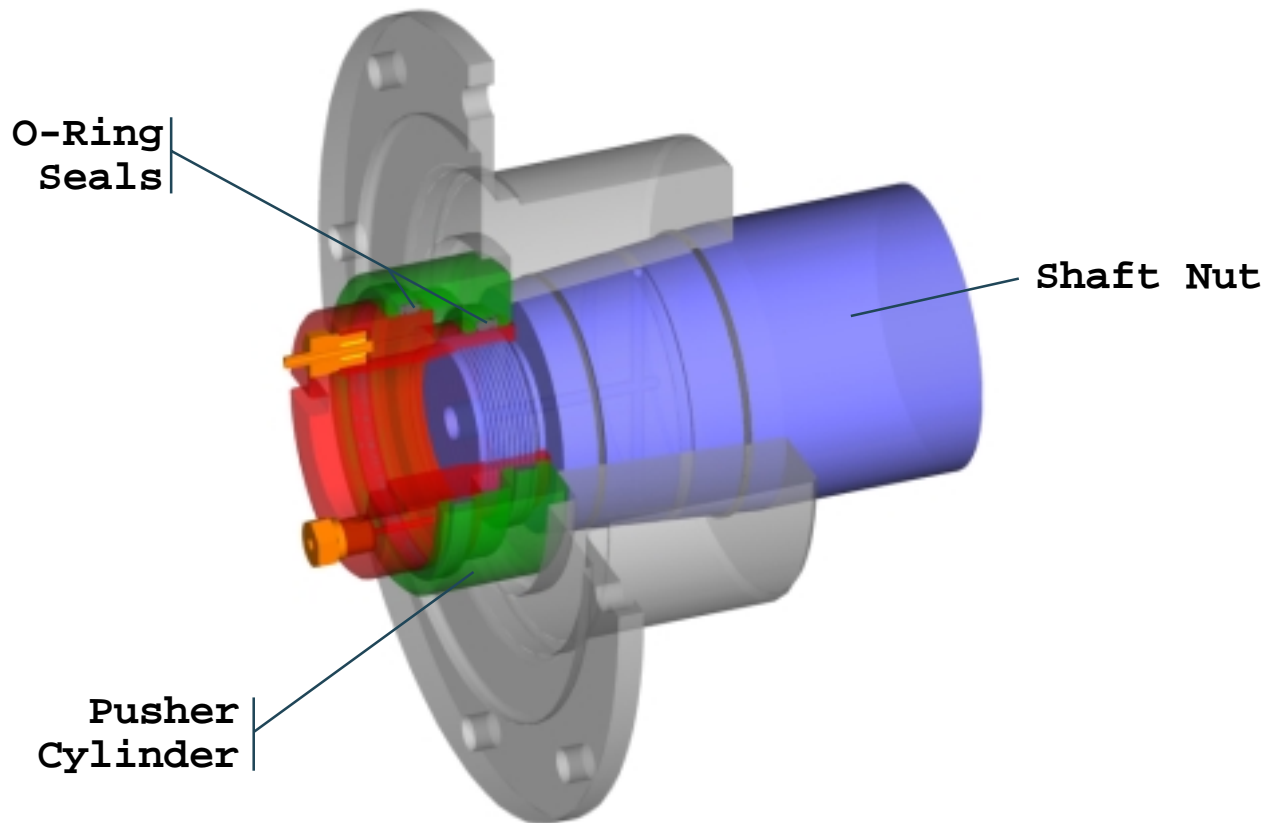

Hydraulic Installation Kits

To ease the installation of hydraulic shaft elements, Riverhawk has developed a hydraulic installation kit. The kit consists of two pumps and their associated gauges mounted on a welded tubular steel sled with all the necessary fittings and two high pressure hoses needed for your installation. The hoses can be readily flexed to a 10 inch radius for use or

storage. The hoses are both rated for the higher pressure, thus are safely interchangeable. The complete kit comes in a reusable rugged plastic storage container, so everything is there when needed the next time a component has to be installed or removed.

Riverhawk Company, an engineering driven manufacturer, specializes in hydraulic shaft joining technologies. We meet the daily challenges of the rotating equipment industry by offering auxiliary equipment such as air driven and manual hydraulic pressure kits and pusher piston cylinders for the installation of coupling hubs, thrust discs, and compressor wheels. Riverhawk also designs and manufactures hydraulically tensioned studs and nuts, tensioning tools, hydraulic nuts, and plug and ring gages. We also provide source inspections and training seminars. Our equipment is proudly supplied to the top OEMs and end users of the turbomachinery industry. Riverhawk is a member of the American Petroleum Institute (API) and sits on the coupling committee of the American Gear Manufacturers Association (AGMA).

For more information about Riverhawk's Pusher Piston/Cylinders or any of our other products and services call



215 Clinton Road, New Hartford, NY 13413

Phone: 315-768-4855 Fax: 315-768-4941

sales@riverhawk.com <http://www.riverhawk.com>