

VISCOUS ROTATIONAL DAMPER®

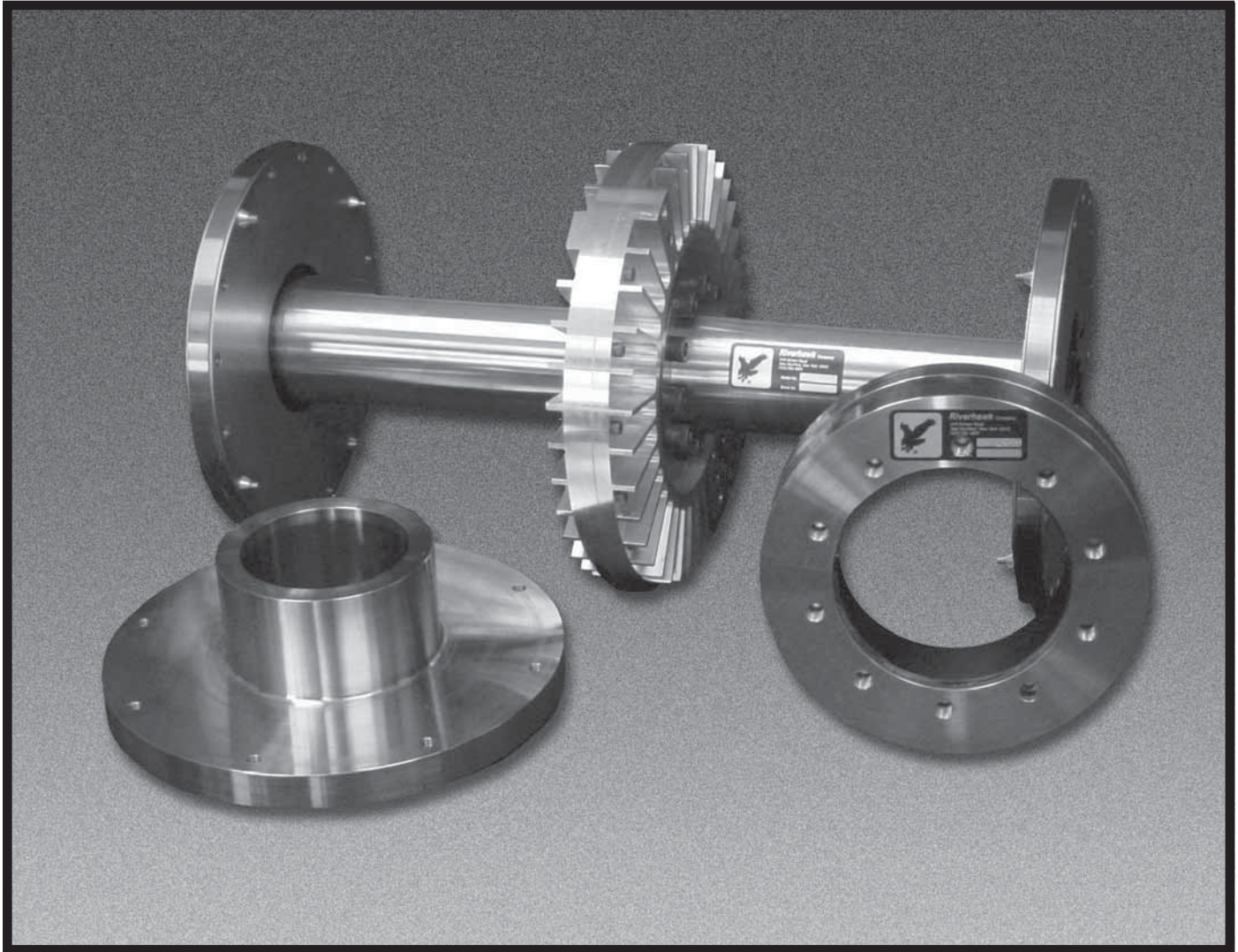

The Riverhawk Viscous Rotational Damper (VRD) is a mechanism that transmits continuous torque and protects connected machines by damping alternating torque vibrations. It is designed to fit in the space between separated machinery

shafts. The VRD can be applied two ways. It can be fitted directly between the ends of machinery shaft where it accommodates small misalignments as a quill or it can be mounted between the flex elements of a flexible coupling forming the spacer

portion of the coupling. This approach provides the equipment designer with the advantage of being able to mate the VRD to flex elements of choice while allowing design for damped torsional natural frequencies.

Features and Benefits

- Compact and light weight design
- No elastomeric elements to degrade or overheat
- Efficient heat dissipation
- Superior damping and stiffness linearity
- Independent tuning of damping and stiffness



DESIGN AND OPERATION

A quill shaft, designed to transmit steady torque, is connected to flanges at both ends. These flanges, in turn, are designed to connect with either coupling flex elements or directly to the mating machines. The damping assembly, consisting of two halves, is positioned over the center section of the quill shaft. Torque tubes mount to each end of the quill shaft and extend to the center where they connect to the damping assembly. The damping

assembly consists of a housing and a plate. The housing fastens to one torque tube and the plate connects to the other. Between the housing and the plate is a viscous fluid.

The quill shaft twists when torque is applied to the Viscous Rotational Damper (VRD). This twisting action causes the housing and plate to rotate relative to one another shearing the viscous fluid and causing a small amount of energy

to be absorbed. When an alternating torque is applied, energy is absorbed for each cycle. The greater the alternating torque input, the greater the absorption of energy. This action dampens out torsional vibration and protects connected equipment.

Dampened energy is converted to heat where it absorbs into the housing and is quickly dissipated into the surrounding air.

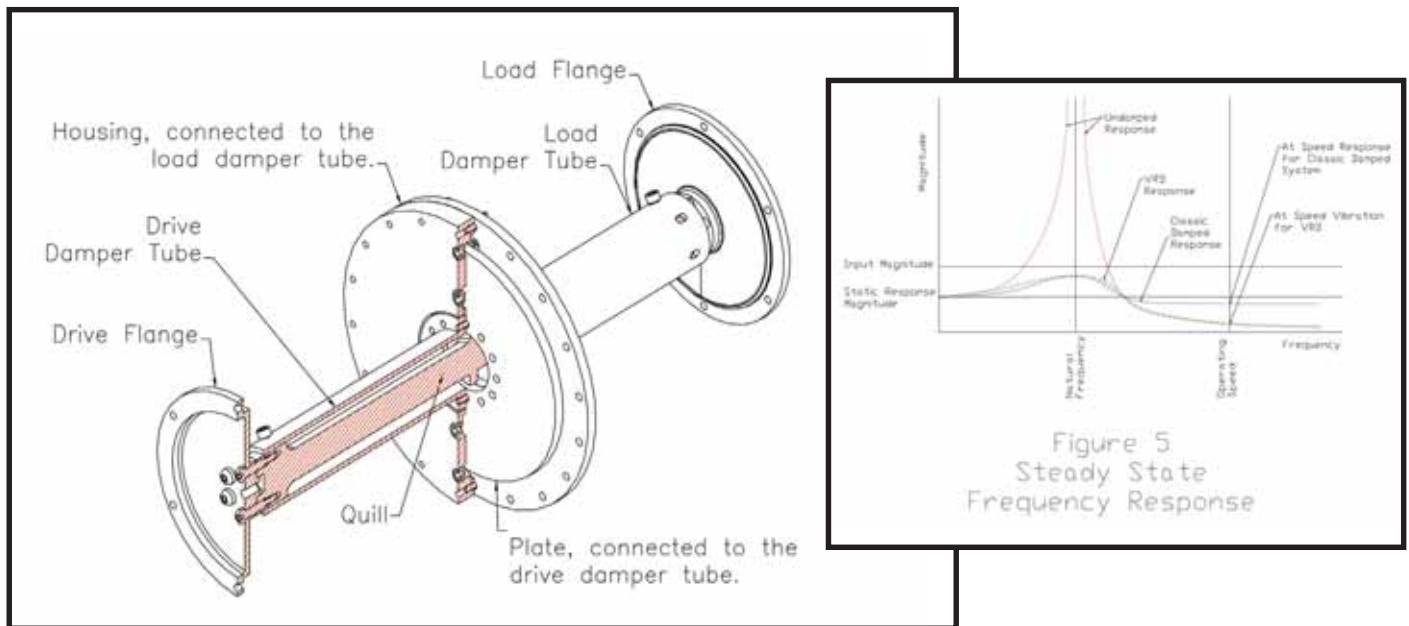

Disclaimer

The information contained within this document is based upon certain assumptions about equipment design and operation as foreseen at the time of publication. The equipment designer / user is assumed to be familiar with the equipment and its operation. For this reason the equipment designer must assume responsibility for the proper applications of the Riverhawk VRD to the subject equipment.

Riverhawk Company, an engineering driven manufacturer, specializes in hydraulic shaft joining technologies. We meet the daily challenges of the rotating equipment industry by offering auxiliary equipment such as air driven and manual hydraulic pressure kits and pusher piston cylinders for the installation of coupling hubs, thrust discs, and compressor wheels. Riverhawk also designs and manufactures hydraulically tensioned studs and nuts, tensioning tools, hydraulic nuts, and plug and ring gages. We also provide source inspections and training seminars. Our equipment is proudly supplied to the top OEMs and end users of the turbomachinery industry. Riverhawk is a member of the American Petroleum Institute (API) and sits on the coupling committee of the American Gear Manufacturers Association (AGMA).

For more information about Riverhawk's Viscous Rotational Damper (VRD) or any of our other products and services call:



215 Clinton Road, New Hartford, NY 13413
Phone: 315-768-4855 Fax: 315-768-4941
sales@riverhawk.com <http://www.riverhawk.com>